



Manhole Products

48" Type 3 Precast Manhole WSDOT B-15.60-02

Grade Adjustment Rings Available

- 2", 3", 4", 6"

Hole or Knock Out Dimensions

- Maximum hole size is 36 inches
- 8 inches of minimum distance between holes
- 2 inch diameter lifting holes provided
- Cored, cast-in and custom block-out/knock-outs available

Conformity Standards

- ASTM C478 Manhole
- ASTM C443 rubber gasket joint
- ASTM D4101 polypropylene steps and ladders
- Washington State APWA / WSDOT Standard

Options Available

- Pre-channeled base
- Predl Systems Monolithic GU Lined Base
- Specialized coatings
- Kor-N-Seal boots
- 1' thru 10' Polypropylene ladders

Section Specifications

Height	Section	Base
6"	410 LBS	-
12"	859 LBS	1,859 LBS
24"	1,735 LBS	2,735 LBS
36"	2,612 LBS	3,612 LBS
48"	3,489 LBS	4,489 LBS
60"	4,365 LBS	5,365 LBS
72"	5,069 LBS	6,069 LBS

Base Slab	Flat Top
1,698 LBS	1,667 LBS

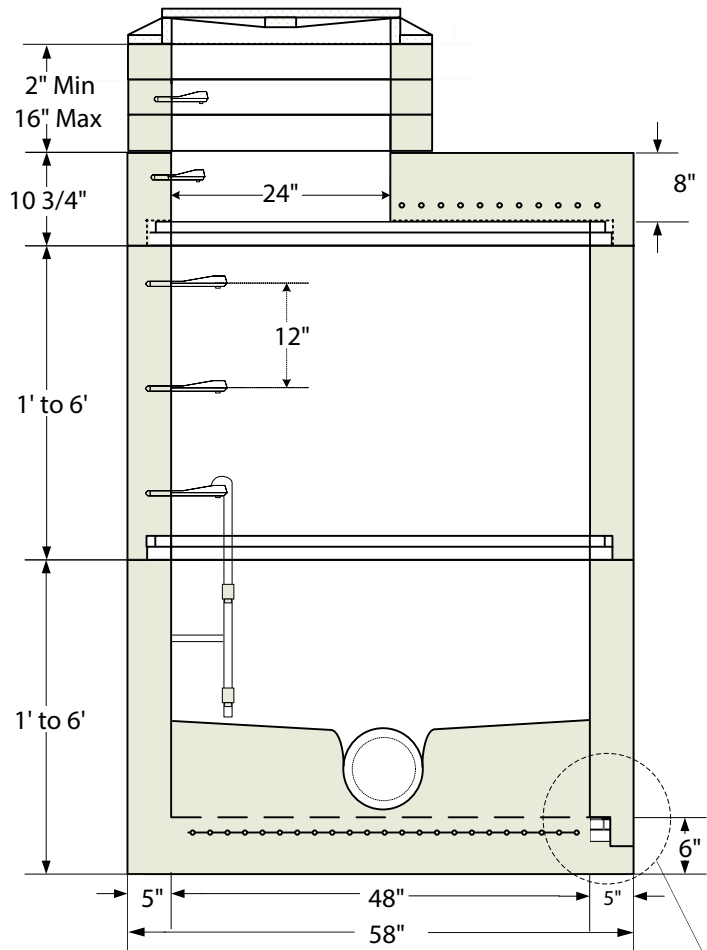

Top Slab Plan View

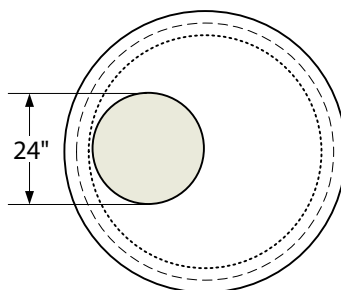

Gasket Shown Uncompressed

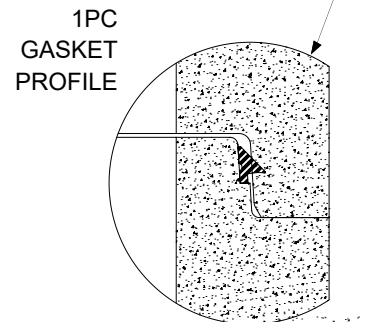

Note: Drawings not to scale

www.shopeconcrete.com

1-800-422-7560 [TOLL FREE]



Shope Concrete, LLC
1618 East Main Avenue
Puyallup, WA 98372-3142

(253) 848-1551
Fax Line 1 (253) 845-0292
Fax Line 2 (253) 864-6172

